

YZF-R15('17) TIS FULLSYSTEM GP-MAGNUM

Be sure to read the instruction carefully before starting the work. It is necessary to follow the contents to install Yoshimura product.



- CAUTION** Before beginning installation, let motorcycle cool down.
- CAUTION** Be sure not to damage each part during installation.
- CAUTION** Torque specification must be followed. If neglected, it may cause bolt and nut to fall off and damage to Yoshimura product and motorcycle.
- CAUTION** Metal Magic sleeve is coated with heat-resistant paint. Handle with care not to be hit or scratched by surroundings as the coating may come off. When cleaning silencer, use soft cloth with dish soap but do not use metal polish or chemical cleaner.
- CAUTION** Titanium Blue sleeve is colored by anodizing. Handle with care as the color may change. When cleaning silencer, use soft cloth with dish soap but do not use metal polish or chemical cleaner.

1. Product Information :

Description	YAMAHA YZF-R15('17) TIS FULL SYSTEM GP-MAGNUM			
Part Number	Stainless Sleeve (SS)	: 1T0A-366-5U50	Cyclone Type	Y366SCI11
	Titanium Sleeve (ST)	: 1T0A-366-5U80	Main Material	Stainless steel
	Titanium Blue Sleeve (STB)	: 1T0A-366-5U80B	Weight [STD : 4.7kg]	(SSF) & (SM) : 2.9kg
	Carbon Sleeve (SC)	: 1T0A-366-5U90		(STB) : 2.7kg

2. Applicable Model :

Model	YAMAHA YZF-R15('17)
	YAMAHA MT-15('18)

3. Contents:

No.	Descriptions	Part No.	Q'ty	No.	Descriptions	Part No.	Q'ty
1	Exhaust Pipe#1	1T1-366-C200	1	8	Washer M8x26	812-108-2600	2
2	Exhaust Pipe#2 GP-Magnum	1T2-366-5U00	1	9	Flange Nut M8	823-008-1250	2
3	Silencer Assy Stainless Sleeve	1T6-366-5U50	1	10	Button Bolt M6x20	803-206-4020	2
	Silencer Assy Titanium Sleeve	1T6-366-5U80		11	Washer M6x13	812-206-1310	2
	Silencer Assy Titanium Blue Sleeve	1T6-366-5U80B		12	Flange Nut M6	823-006-1000	2
	Silencer Assy Carbon Sleeve	1T6-366-5U90		13	Exhaust Spring	118-001-0000	2
4	Flange	117-038-0000	1	14	Spacer 10-26-6	850-010-26A0	1
5	Silencer Bracket	161-366-0200-01	1	15	Spacer 8-26-5	850-008-2605	1
6	Cap Bolt M8x20	800-208-5020	1	※	Spring Puller Tool	100-000-0000	1
7	Cap Bolt M8x50	800-208-5050	1				

Parts Diagram

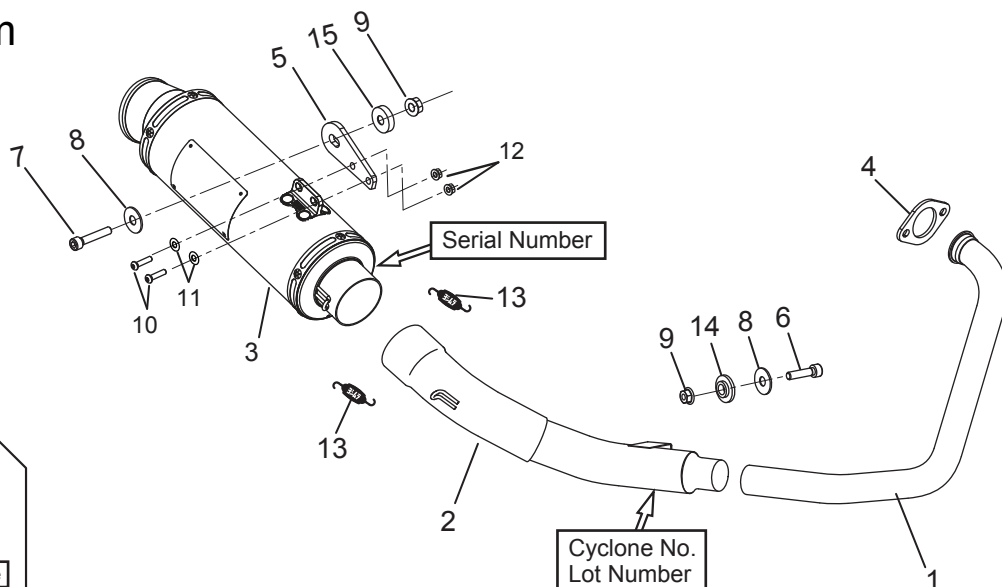

4. Installation steps:

- 1) Check all the component parts are in hand.
- 2) According to YAMAHA service manual, remove right hand side and under fairings. Then, remove stock exhaust system from vehicle (See Fig. 1) .

CAUTION When removing stock exhaust system, be careful not to damage frame and other components.

REFERENCE Stock nuts removed at this stage are reused when mounting Yoshimura exhaust system.

- 3) Install Flange to Exhaust Pipe#1 (See Fig. 2).
- 4) Insert YAMAHA genuine new exhaust gasket in exhaust port. Then, insert Exhaust Pipe#1 into exhaust port and fix them with stock nuts (See Fig. 3 & 4). Tighten nuts by hand only at this stage.

CAUTION Use YAMAHA genuine new gasket

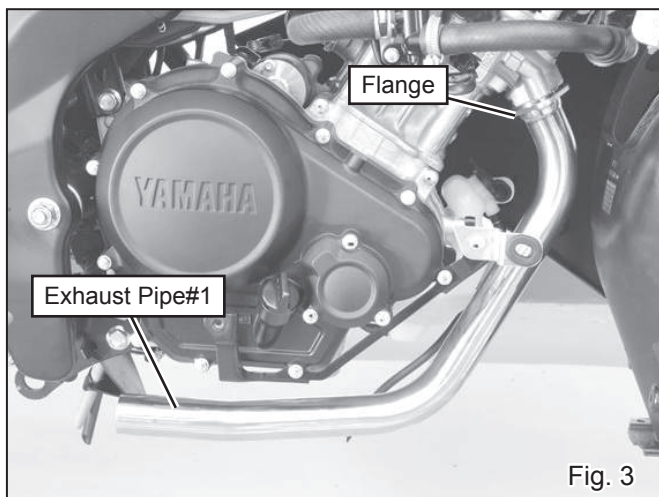

Fig. 3

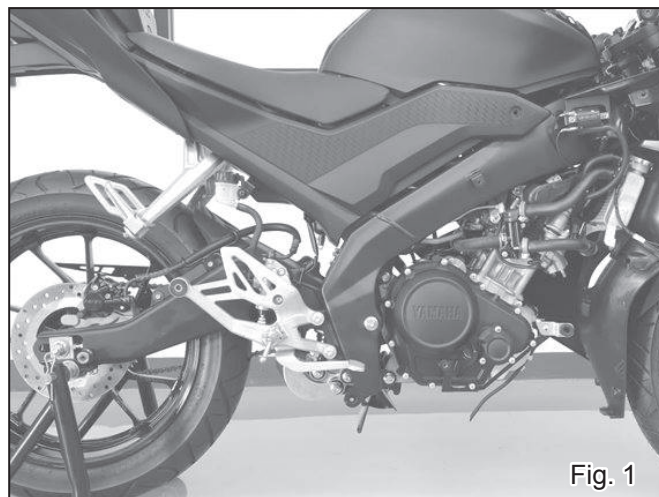

Fig. 1

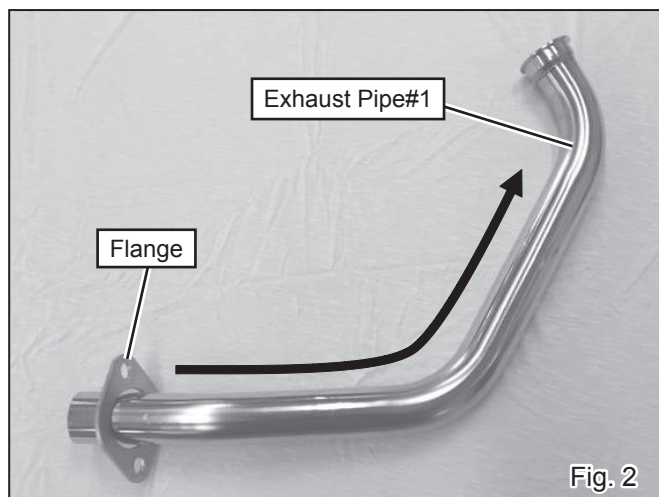

Fig. 2

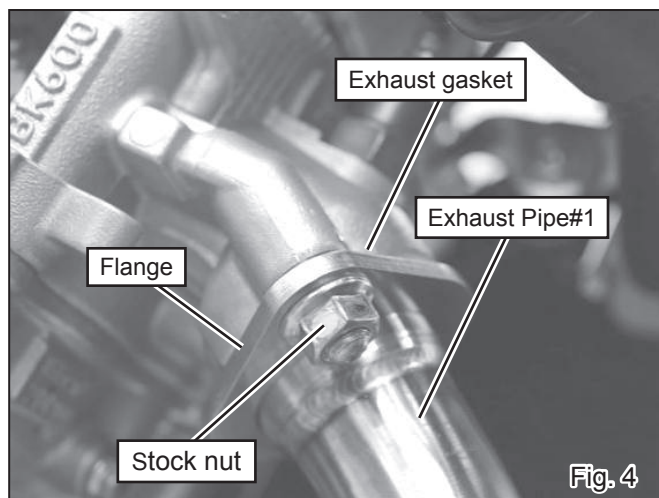

Fig. 4

- 5) Install Exhaust Pipe#2 into Exhaust Pipe#1. Then, mount exhaust pipe bracket to stock exhaust bracket with Cap Bolt M8x20, Washer M8x26, Spacer 10-26-6 and Flange Nut M8 (See Fig. 5 & 6).

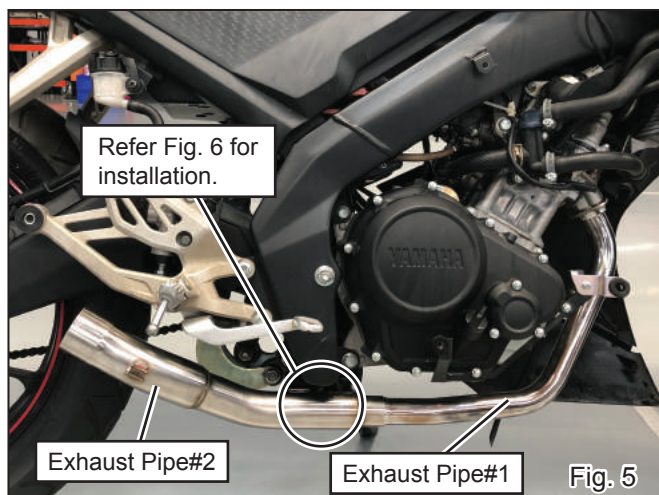

Fig. 5

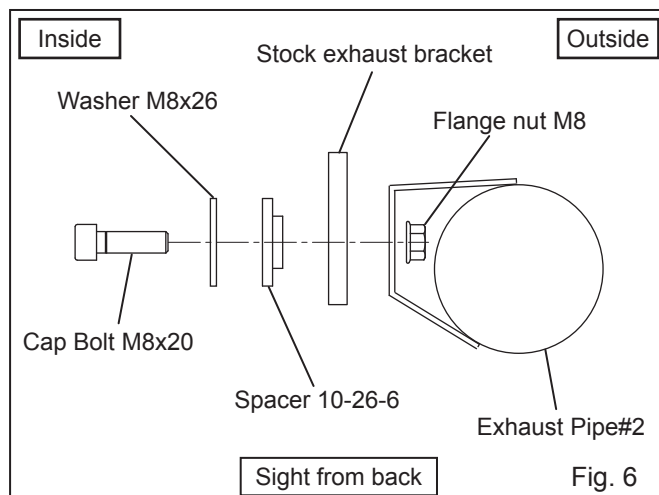
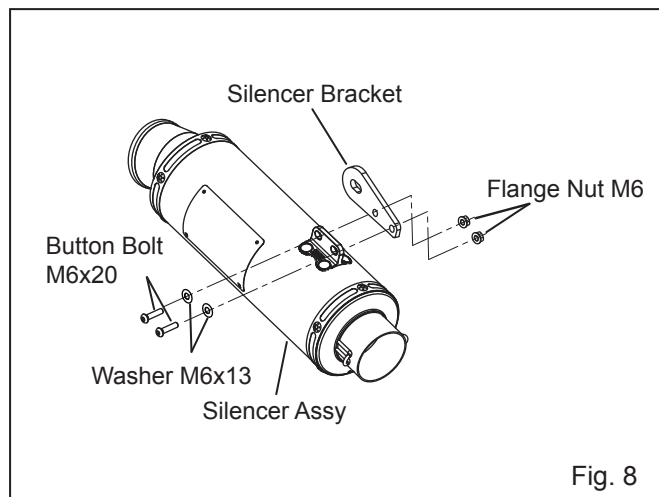
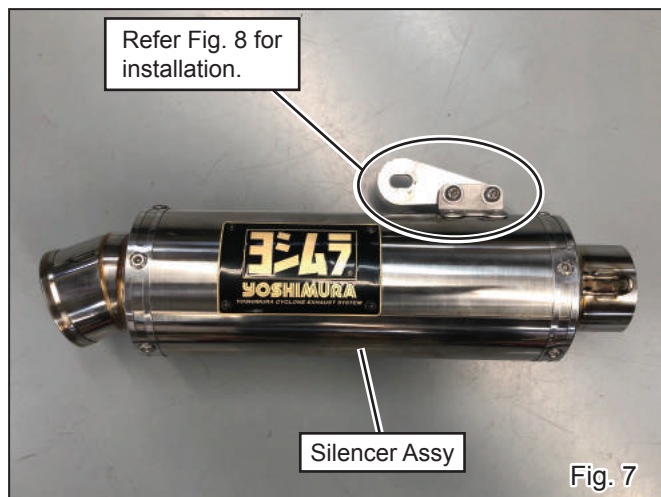

Fig. 6

- 6) Attach Silencer Bracket onto Silencer Assy with 2 of each Button Bolt M6x20, Washer M6x13 and Flange Nut M6 (See Fig 7 & 8). Tighten the bolts by hand only at this stage.



- 7) Install Silencer Assy to Exhaust Pipe#2 and fix them with Exhaust Spring (See Fig. 9).

CAUTION Make sure that exhaust spring is hooked to spring installation tool firmly. If neglected, it may cause injury.

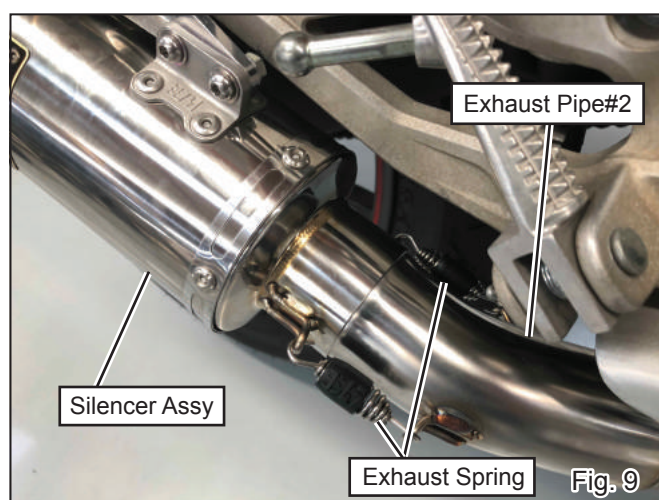

- 8) Mount Silencer Bracket to stock silencer bracket with Cap Bolt M8x50, Washer M8x26, Spacer 8-26-5, Flange Nut M8 and stock washer (See Fig. 10 & 11) Tighten the bolt by hand only at this stage.

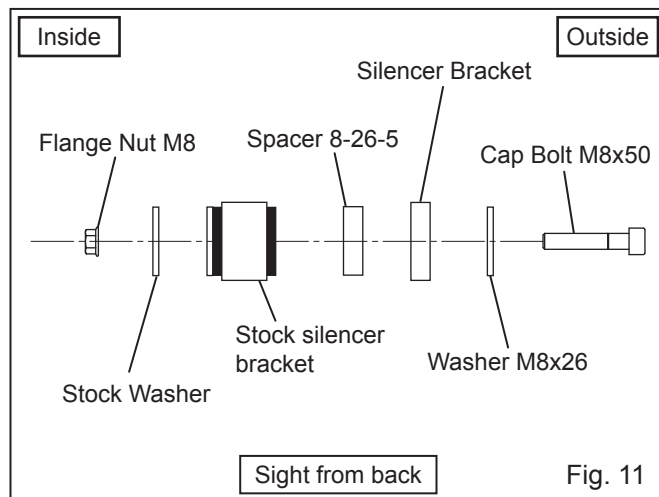
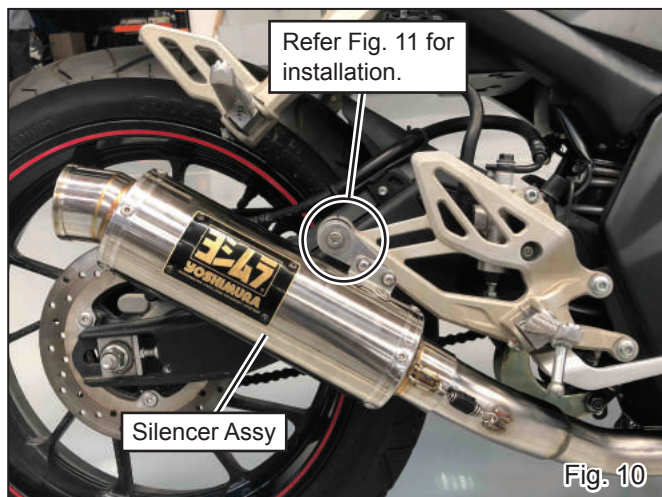

- 9) Check that there are proper clearances between Yoshimura exhaust system and other components. Then, tighten and torque stock nuts on Flange, Cap Bolt M8x20, Button Bolt M6x20 and Cap Bolt M8x50 in order (See Fig. 12 on next page).

Tightening Torque	Stock Nut	: 15Nm
	Cap Bolt M8x20	: 23Nm
	Button Bolt M6x20	: 10Nm
	Cap Bolt M8x50	: 23Nm

CAUTION Make sure stock nuts on Flange are tighten evenly. If neglected, it may cause the exhaust leakage and/or interfere the fairing.

CAUTION Torque specification must be followed.

- 10) Make sure there are proper clearances between Yoshimura exhaust system and other components. In case there is not enough clearance, loosen bolts and nuts and readjust the position of Yoshimura exhaust system.
- 11) It is recommended that whole Yoshimura exhaust system to be wiped down with dish soap to remove oil and fingerprints. This will prevent tarnishing of finish after the slip-on is heated up.

CAUTION When cleaning silencer, use soft cloth with dish soap. Do not use metal polish or parts cleaner. If neglect, the paint of Emblem and Metal Magic finish may come off or Titanium Blue color may tarnish.

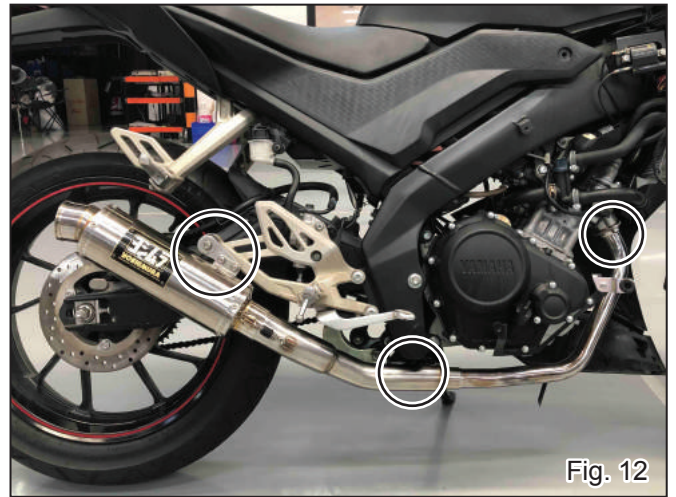

Fig. 12

- 12) Re-mount side and under fairings.
- 13) Warm-up engine, inspect the exhaust leakage. Tighten all bolts and nuts further after engine is cooled down.

CAUTION If the exhaust leakage is detected, seal the area with silicone gasket etc.

REFERENCE It is normal for new silencer to smoke until inside oil residue burns off.

After Installation



YAMAHA YZF-R15

After Installation



YAMAHA MT-15

CAUTION

Titanium Blue sleeve is colored by anodizing. Handle with care as the color may change. When cleaning silencer, use soft cloth with dish soap but do not use metal polish or chemical cleaner.

CAUTION

This exhaust is produced for street use only. In case that it is used on race circuit or tested on chassis dynamometer, any damage or carbon discoloration is not included in warranty.

REFERENCE

Yoshimura Asia recommends silencer inner wool replacement every 5,000km (3,000miles) in order to get Yoshimura exhaust performance fully. Climate, riding condition, and frequency of ride are direct contributing factors for inner wool worn out. Keeping high engine revolution also promotes further wool consumption. For silencer repairing, please contact local Yoshimura distributor for further information.

- CAUTIONS AFTER INSTALLATION -

- ⊙ Check each bolt sometimes to see that there is no failure condition such as poor tightening.
- ⊙ Quality control is implemented on all products. If, however, any defect or failure is found, please notify Yoshimura Asia through the selling dealer. Necessary technical service or replacing of the product will be made.
- ⊙ Due to improvement, the specifications and price of the product are subject to change without notice.
- ⊙ For any information regarding this product, please address inquiries to Yoshimura Asia Co., Ltd.

Yoshimura Asia Co.,Ltd.

118/3 MOO 18 KLONG NUENG , KLONG LUANG , PATHUMTHANI 12120 THAILAND

Web site : <http://www.yoshimura.asia>